

Project: WIPO Digital Access Service (DAS)

DAS Architecture: Document Exchange and Dataflow

Revision 1.3



**WORLD INTELLECTUAL PROPERTY
ORGANIZATION**

GENEVA

Table of Contents

1	DAS Architecture: Document Exchange and Dataflow	4
1.1	Brief Description.....	4
1.2	Terminology.....	4
2	Implementation of the DAS system.....	5
2.1	Security requirements	5
2.2	Software components.....	5
2.2.1	The front-ends.....	5
2.2.2	The middle-tier.....	5
2.2.3	The back-end.....	5
2.3	External accesses to DAS resources	6
2.4	Initial setup.....	6
2.5	Current participating Offices	6
2.6	PCT-EDI batch files.....	6
2.6.1	Folder Structure.....	6
2.6.2	Request batch and index files.....	7
2.6.3	Response batch and index files	8
2.6.4	Current version of library-transaction.dtd.....	9
2.6.5	Requests and Responses for PDOC Entry	9
2.6.6	Requests and Response for PDOC document and information	12
2.6.7	Error handling	14
2.6.8	Possible errors.....	15
2.6.9	Temporary responses	15
2.6.10	Recommended file naming convention.....	17
2.6.11	Supported file formats.....	17
2.7	Cover page for priority documents	18
2.8	Usage of application numbers.....	18
2.8.1	Add PDOC entry to DAS.....	19
2.8.2	Retrieve PDOC from DAS.....	19
2.9	Optional business data	19
2.10	Bilateral arrangement.....	19
3	Flow of data for Route A or B	20
3.1	OFF to DAS	20
3.2	OSF to DAS via PCT-EDI.....	21
3.3	OSF to DAS via TDA	22
3.4	Web Applicant to DAS (manage access control list).....	24
3.5	Web Applicant to DAS (query PDOC availability).....	26
3.6	OSF to DAS via PCT-EDI (query PDOC availability)	27
4	Recommendations for implementation	28

Change Log

Chapter	Version	Date	Comments
All	1.0	27/06/2008	Initial version
All	1.1	17/07/2008	Update participating offices list for the initial setup of DAS (paragraph 2.4) Add description to highlight difference between ADD-ENTRY and ADD-DOCUMENT operations (paragraph 2.6.5)
2	1.2	30/09/2009	Update participating offices list for DAS (paragraph 2.4) Added paragraphs to give details about: <ul style="list-style-type: none">- current participating offices (paragraph 2.5)- library-transaction.dtd (paragraph 2.6.4)- handling of errors (paragraph 2.6.7)- possible errors (paragraph 2.6.8)- temporary responses (paragraph 2.6.9)- recommended file naming convention (paragraph 2.6.10)- supported file format (paragraph 2.6.11)- cover page (paragraph 2.7)- usage of application numbers (paragraph 2.8)- optional business data (paragraph 2.9)- Bilateral arrangement (paragraph 2.10)
2	1.3	18/11/2009	Corrections: <ul style="list-style-type: none">- wrong third screenshot is replaced (paragraph 2.6.2)- replace all screenshots referring to language code 'xx' by upper case 'XX'- added error code '-11' (paragraph 2.6.8)- samples referred to DTD version 1.2

1 DAS Architecture: Document Exchange and Dataflow

1.1 Brief Description

The purpose of this document is to describe the implementation of the DAS system in accordance with the system architecture, agreed principles and framework provisions established by the International Bureau in accordance with the agreement by the Working Group on the Digital Access Service for Priority Documents. It principally aims at illustrating how documents are exchanged over PCT-EDI framework and how the communication of requests and responses are handled among Office of First Filing (OFF), Office of Second Filing (OSF) and the Digital Access Service (DAS). Several scenarios are considered in this document: Add Priority Documents (PDOC) to DAS, Retrieve PDOCs from DAS, Manage Access Control List and Query PDOC availability.

1.2 Terminology

Trilateral Document Access (TDA) is the document exchange system used by the Trilateral Offices: USPTO, EPO and JPO. It is implemented as web services and operated over a secure network.

Office of First Filing (OFF) is the term used to refer to an Office whose digital library holds the copy of a document which is to be accessed by other Offices. This equates to the term "depositing Office" in the Framework Provisions. It should be noted that, for the purpose of this document, the term extends not only to the actual Office of First Filing, but to any other Office which holds a verified copy of the relevant document (for example, because it has been filed as a priority document in respect of a later application) and which makes it available through the system. This terminology is used rather than the more exact "depositing Office" because of the wide understanding of the term OFF in the context of the most important actual usage of the system.

Office of Second Filing (OSF) is the term used to refer to an Office which wishes to retrieve a copy of a document which is held by an OFF. This equates to the term "accessing Office" in the Framework Provisions. The term is used here because it is in current widespread use to describe the most important (and initially only) usage of this role by an Office dealing with an application which claims priority from an earlier application, the latter being the document to be accessed.

PCT-eDossier is an integrated software solution for internal WIPO use, designed to provide examiners, translators and other users within the PCT with electronic facilities to effectively manage PCT document work-flow and bibliographic data of International Applications (IA) filed either on paper or electronically.

PCT-EDI is the document exchange system used by WIPO and Offices. It is implemented and operated over SFTP. DAS requests and responses for PDOC exchange operations are structured as XML files. At the time of writing this use case, a DTD is made available as version 1-0 (library-transaction-v1-0.dtd). Some sample instances of the XML are given in this document.

Web Container is a web server that provides a set of resources and services.

[Minimal Specifications for Electronic PCT Document Exchange](#) provides an easily implemented, temporary yet upward extensible solution to the problem of electronic document exchange between the International Bureau, Patent Cooperation Treaty (PCT) member state intellectual property offices and PCT international authorities.

2 Implementation of the DAS system

2.1 Security requirements

One of the major security requirements is to protect the business processes and some unpublished data stored in DAS. Consequently, the business processes should be deployed inside the WIPO LAN and be accessible to external users only through dedicated proxy servers and firewalls.

2.2 Software components

The software and hardware environments of the DAS system are built on top of a 3-tier architecture and include the following components.

2.2.1 The front-ends

A front-end framework that exposes all DAS services to external users Applicants and Offices users. It is responsible for capturing service requests and storing them in the appropriate requests queues. It supports three types of communication channels:

- A dedicated web portal over HTTPS provides online access to Applicant to setup the access control list and query DAS for priority documents availability.
- A SFTP server provides the PCT-EDI framework to allow communications between OFF/OSF and DAS. Each office SFTP account contains a home directory with two main folders **to-das** and **from-das**. The exchange communication is only based on file transfer mechanism. In addition to the server, there is also a trigger process listening to any SFTP disconnection events. Upon disconnection from the OFF or OSF, the trigger process identifies incoming requests and converts all input data into a request object and forward it to the middle-tier components.
- A TDA gateway (Web Services container) provides the TDA framework to support communications between OFF/OSF and DAS on a dedicated secure network.

2.2.2 The middle-tier

A middle-tier framework is responsible for handling all incoming requests, dispatching them to the appropriate back-end process and sending back the processing results such as requested document or business information. System failover, regular backup and load balancing will be implemented to ensure a high availability and reliability of the DAS system, independently of the availability of other systems operated in Offices. Server machines deployed in this area are not exposed to the public access. They are protected by firewalls and require appropriate access credentials.

2.2.3 The back-end

A back-end framework that applies the business processes to fulfil incoming requests and provides the requested information in response. Server machines deployed in this area are not exposed to the public access. They are protected by firewalls and require appropriate access credentials. Several components are deployed on these servers:

- Several business processes are implemented as listeners to the previous queuing servers so that they can be triggered to perform the proper business processing based on the requests.
- A database that stores and tracks requests and responses of all exchange operations and business information related to priority documents
- A document management service provides the capacity to store and serve document content. It is used only for documents that are stored inside the DAS system.

- A e-mail service that is used for the back-end processes to notify applicants and offices
- A web-based monitoring system provides facilities to DAS operators to detect and handle exceptions (e.g. TDA system scheduled downtime, TDA re-requests scheduling if needed)

2.3 External accesses to DAS resources

External accesses to DAS resources are made available through several protocols:

- OFF and OSF can communicate with DAS by submitting requests and retrieving responses, using SFTP under PCT-EDI.
- OFF and OSF can communicate with DAS by submitting requests and receiving responses, using SOAP under TDA.
- Applicant can access to DAS through a dedicated web portal supporting only HTTPS.

2.4 Initial setup

After consultation of some pilot Offices (EPO, JPO, FIPO, ILPO, SIPO, UK-IPO and USPTO) that have expressed their interest in joining the initial deployment of DAS, we are targeting in a first delivery of DAS supporting the following communications:

- OFFs that implement Route A or B would use PCT-EDI infrastructure and therefore use it also for other exchanges as OSF. Offices that implement PCT-EDI may choose to host priority documents content in their own repository or to store them in DAS, but priority document numbers are always added to DAS.
- OFFs that implement Route C would use TDA infrastructure and therefore use it also for other exchanges as OSF. Offices that implement TDA would host priority documents content and only priority document numbers are added to DAS.

2.5 Current participating Offices

The last update on participating offices includes the following offices and launch dates, which is published on the DAS portal and regularly updated if new offices join:

- IB and JP April 1, 2009.
- US April 20, 2009.
- KR July 1, 2009.
- ES October 1, 2009.
- GB October 5, 2009.

2.6 PCT-EDI batch files

Any exchange between DAS and an office is done through a batch file transfer mechanism.

2.6.1 Folder Structure

For a participating office which uses PCT-EDI (i.e. CN), only the two sub-folders **to-das** and **from-das** are visible under the root folder.

When the exchange is initiated from an Office, a batch request file is used for requesting information to DAS (e.g. **to-das** folder) and batch response files are used to provide responses from DAS (e.g. **from-das** folder). One DAS request file may refer to many request items of PDOC information and/or document content.

Similarly, when the exchange is initiated from DAS to an Office, a batch request file is used for requesting information to Office from DAS (e.g. **from-das** folder) and batch response files are used to send responses to DAS from Office (e.g. **to-das** folder).

For each request batch, a sub folder under **from-das** is created with the same name of the request batch file without the file extension. The following example is a snapshot for CN:

- 2 request batch files are sent to DAS.
- Response batch files are provided by DAS in reply to the previous requests
 - 1 folder has 2 response batch files because of 2 requested operations, 1 original index request file and 1 response status file because all responses are provided
 - 1 folder has 4 response batch files because of 4 requested operations, 1 original index request file and 1 response status file because all responses are provided
- 1 request batch is sent to CN from DAS
- 1 response is given by CN to DAS
 - 1 folder has 1 response batch file because of 1 requested operation, 1 original index request file and 1 response status file because all responses are provided

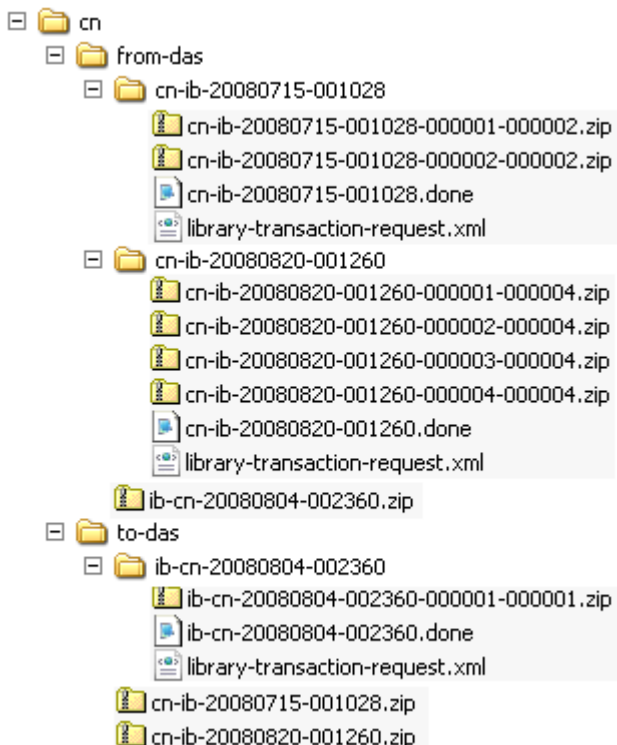

2.6.2 Request batch and index files

The file name of the request batch file is RR-PP-yyyymmdd-nnnnnn.zip, where RR and PP are the ST.3 office codes of the requesting and providing offices, yyyymmdd is the uploading date of the batch, nnnnnn of the unique sequence number of the year (e.g. ib-cn-20080804-002360.zip).

The request batch file should contain one single index file named as **library-transaction-request.xml**. It should provide some mandatory information (dtd-version, file, transaction-type, date-produced, country, sending-office, recipient-office) and specifies a list of operations and library-entries.

```
<?xml version="1.0" encoding="UTF-8"?>
<!--Sample XML file created for testing DAS System-->
<!DOCTYPE library-transaction SYSTEM "library-transaction-v1-2.dtd">
<library-transaction dtd-version="1.2" lang="en"
  file="library-transaction-request.xml"
  transaction-type="request"
  transaction-id="ib-cn-20080804-002360.ZIP"
  date-produced="20080804"
  country="IB" sending-office="IB" recipient-office="CN">
  <retrieval-request-list>
    <retrieval-request operation="get-document">
      ...
    </retrieval-request>
  </retrieval-request-list>
</library-transaction>
```

Depending on the requested operation, priority document files may also be provided in the batch.

The following example is a batch request cn-ib-20080715-001028.zip that retrieves priority documents from DAS, so it contains only the index file **library-transaction-request.xml**.



The following example is a batch request cn-ib-20080820-001260.zip that adds one priority document to DAS by providing the index file **library-transaction-request.xml** and the documents content **XXXXXXXXXXXX-pdoc-000001-EN-JP-XXXXXXXX-122900-20080822.zip**.

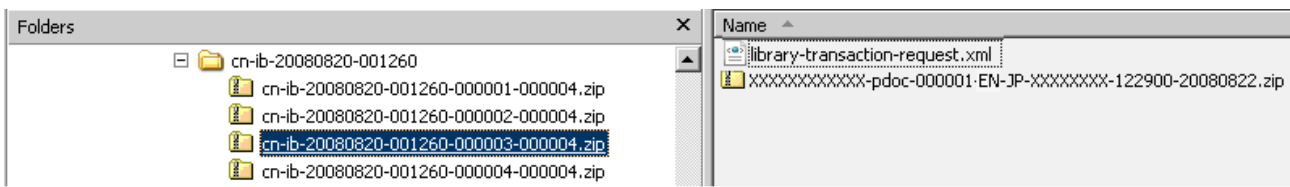

2.6.3 Response batch and index files

The file name of the response batch file is RR-PP-yyyymmdd-nnnnnn-xxxxxx-NNNNNN.zip, where RR and PP are the ST.3 office codes of the requesting and providing offices, yyyymmdd is the uploading date of the batch, nnnnnn of the unique sequence number of the year (e.g. cn-ib-20071104-001625-000001-000002.zip), xxxxxx is the sequence number of the library-entry

described in the index file **library-transaction-request.xml**, NNNNNN is the total number of requested library-entries.

When the responses are provided by DAS, they will be given in individual response batch file because each response may be found in DAS or result from a query to the OFF. To facilitate reading of the responses from DAS the original index file **library-transaction-request.xml** is added to each response sub folder. Once all responses are provided by DAS, an empty text file is created with the name of response folder and suffixed by **‘.done’** (please refer to the above example).

Response index file should provide some mandatory information (dtd-version, id, transaction-id, file, transaction-type, date-produced, country, sending-office, recipient-office).

```
<?xml version="1.0" encoding="UTF-8"?>
<!--Sample XML file created for testing DAS System-->
<!DOCTYPE library-transaction SYSTEM "library-transaction-v1-2.dtd">
<library-transaction dtd-version="1.2" lang="en"
  file="library-transaction-response.xml"
  transaction-id="ib-cn-20080804-002360.ZIP"
  transaction-type="response"
  id="ib-cn-20080804-002360-000001-000001.ZIP"
  date-produced="20080804"
  country="CN" sending-office="CN" recipient-office="IB">
  <retrieval-request-list>
    ...
  </retrieval-request-list>
</library-transaction>
```

Two important items of information are present: attribute **id** refers to the response folder name inside **from-das** folder and **transaction-id** contains the original request file name.

2.6.4 Current version of library-transaction.dtd

The latest version of the library-transaction.dtd is published on the DAS portal and it will evolve as requirements emerge in the light of the DAS pilot and consultations with stake holders. Recent changes include the following:

- Add error reporting tags
- Add in-progress status tag

2.6.5 Requests and Responses for PDOC Entry

Requests for PDOC entry support the following operations:

- ADD-ENTRY PDOC in DAS and document content may be required depending on the Route option. One PDOC entry allows only one document content and one translation of each translation language (i.e. Japanese). Any subsequent adding entry request of existing PDOC will be rejected as duplicate.

If document content of the priority document is not provided in the index file, DAS will consider it as hosted in OFF.

The following example contains a request to add two PDOC references and documents content into DAS for one single applicant detail by providing also a default access control list of EP, JP and US. Default access control list of accessing offices is allowed in the DTD as an optional element for future enhancement of the system and should not be considered for the initial setup of DAS. It is also an option for OFF to host priority documents in their own digital library or upload them into DAS by specifying wrapped-document element or not.

```
<storage-request route="A" operation="add-entry">
  <storage-library-entry-list>
    <library-entry-owner-details>
      <library-entry-owner>
        <addressbook lang="en"><name name-type="natural">XXXXXX</name>
          <address><address-1>x1</address-1><address-2>x2</address-2><address-3>x3</address-3>
            <country>FI</country>
          </address>
          <email>xxx@yyy.fi</email>
        </addressbook>
      </library-entry-owner>
      <default-access-control>
        <access-control-list>
          <country-access access="allow"><country>US</country></country-access>
          <country-access access="allow"><country>EP</country></country-access>
          <country-access access="allow"><country>JP</country></country-access>
        </access-control-list>
      </default-access-control>
    </library-entry-owner-details>
    <library-entry appl-type="national">
      <document-id><country>FI</country><doc-number>11/272,866</doc-number></document-id>
      <library-entry-document-list>
        <library-entry-document document-type="pdoc">
          <wrapped-document package-type="wad" file="XXXXXXXXXXXX-pdoc-000001-XX-FI-XXXXXXXX-110272,866-20071203.zip"/>
        </library-entry-document>
      </library-entry-document-list>
    </library-entry>
    <library-entry appl-type="national">
      <document-id><country>FI</country><doc-number>PCT/FI2006/000009</doc-number><date>20071101</date>
      </document-id>
      <library-entry-document-list>
        <library-entry-document document-type="pdoc">
          <wrapped-document package-type="wad" file="XXXXXXXXXXXX-pdoc-000002-XX-FI-20071101-PCT@FI2006@000009-20071203.zip"/>
        </library-entry-document>
      </library-entry-document-list>
    </library-entry>
  </storage-library-entry-list>
</storage-request>
```

In the response file, processing status of the request will be added for each entry as follows:

```
<storage-request route="A" operation="add-entry">
  <storage-library-entry-list>
    <library-entry-owner-details>
      <library-entry-owner>
        <addressbook lang="en"><name name-type="natural">XXXXXX</name>
          <address><address-1>x1</address-1><address-2>x2</address-2><address-3>x3</address-3>
            <country>FI</country>
          </address>
          <email>xxx@yyy.fi</email>
        </addressbook>
      </library-entry-owner>
      <default-access-control>
        <access-control-list>
          <country-access access="allow"><country>US</country></country-access>
          <country-access access="allow"><country>EP</country></country-access>
          <country-access access="allow"><country>JP</country></country-access>
        </access-control-list>
      </default-access-control>
    </library-entry-owner-details>
    <library-entry appl-type="national">
      <document-id><country>FI</country><doc-number>11/272,866</doc-number></document-id>
      <library-entry-document-list>
        <library-entry-document document-type="pdoc">
          <wrapped-document package-type="wad" file="XXXXXXXXXXXX-pdoc-000001-XX-FI-XXXXXXXX-110272,866-20071203.zip"/>
        </library-entry-document>
      </library-entry-document-list>
      <processing-status><complete-success></complete-success></processing-status>
    </library-entry>
    <library-entry appl-type="national">
      <document-id><country>FI</country><doc-number>PCT/FI2006/000009</doc-number><date>20071101</date>
      </document-id>
      <library-entry-document-list>
        <library-entry-document document-type="pdoc">
          <wrapped-document package-type="wad" file="XXXXXXXXXXXX-pdoc-000002-XX-FI-20071101-PCT@FI2006@000009-20071203.zip"/>
        </library-entry-document>
      </library-entry-document-list>
      <processing-status><complete-rejection>PDOC entry not found</complete-rejection></processing-status>
    </library-entry>
  </storage-library-entry-list>
</storage-request>
```

- WITHDRAW-ENTRY PDOC from DAS is supported if it happens before the document is communicated to Offices. Correction of PDOC entry should be handled as two operations WITHDRAW-ENTRY and ADD-ENTRY. Withdrawal of PDOCs that are not recorded in DAS will be rejected as error. Withdrawing a PDOC entry will result in removal of all related documents of the entry (i.e. translations).

Many operations of ADD-ENTRY and WITHDRAW-ENTRY for the PDOC entry are not expected to be used in one request upload. But if that happens, operations will be processed in the order of WITHDRAW-ENTRY and ADD-ENTRY regardless of the order of their presence in the request file.

The following example contains a request to withdraw one PDOC entry from DAS.

```
<storage-request route="A" operation="withdraw-entry">
  <storage-library-entry-list>
    <library-entry appl-type="national">
      <document-id><country>FI</country><doc-number>PCT@FI2006@000029</doc-number></document-id>
    </library-entry>
  </storage-library-entry-list>
</storage-request>
```

In the response file, processing status of the request will be added as follows:

```
<storage-request route="A" operation="withdraw-entry">
  <storage-library-entry-list>
    <library-entry appl-type="national">
      <document-id><country>FI</country><doc-number>PCT@FI2006@000029</doc-number></document-id>
      <processing-status><complete-success/></processing-status>
    </library-entry>
  </storage-library-entry-list>
```

- ADD-DOCUMENT operation is used to add translated priority documents as subsequent requests assuming that the corresponding priority document reference has been recorded in DAS, whereas ADD-ENTRY operation is used for the first transaction of adding new PDOC references/content into DAS.

Overwriting existing document content is not allowed and will be rejected as error. For the initial setup of DAS, translations may not be implemented.

The following example contains a request to add the translation in Japanese of one PDOC in DAS.

```
<storage-request route="A" operation="add-document">
  <storage-library-entry-list>
    <library-entry appl-type="national">
      <document-id><country>FI</country><doc-number>PCT@FI2006@000029</doc-number></document-id>
      <library-entry-document-list>
        <library-entry-document document-type="tpdc" lang="ja"></library-entry-document>
      </library-entry-document-list>
    </library-entry>
  </storage-library-entry-list>
</storage-request>
```

In the response file, processing status of the request will be added as follows:

```
<storage-request route="A" operation="add-document">
  <storage-library-entry-list>
    <library-entry appl-type="national">
      <document-id><country>FI</country><doc-number>PCT@FI2006@000029</doc-number></document-id>
      <library-entry-document-list>
        <library-entry-document document-type="tpdc" lang="ja"></library-entry-document>
      </library-entry-document-list>
    </library-entry>
    <processing-status><complete-success/></processing-status>
  </storage-library-entry-list>
</storage-request>
```

- WITHDRAW-DOCUMENT operation is used to remove existing document content. This operation is not applicable to priority document; WITHDRAW-ENTRY operation should be used to remove both priority document content and entry from DAS. Replacement of document should be handled as two operations WITHDRAW-DOCUMENT and ADD-DOCUMENT.

Many operations of ADD- DOCUMENT and WITHDRAW- DOCUMENT for the document are not expected to be used in one request upload. But if that happens, operations will be processed in the order of WITHDRAW- DOCUMENT and ADD- DOCUMENT regardless of the order of their presence in the request file.

The following example contains a request to withdraw the translation in Japanese of one PDOC from DAS.

```
<storage-request route="A" operation="withdraw-document">
  <storage-library-entry-list>
    <library-entry appl-type="national">
      <document-id><country>FI</country><doc-number>PCT@FI2006@000029</doc-number></document-id>
      <library-entry-document-list>
        <library-entry-document document-type="tpdc" lang="ja"></library-entry-document>
      </library-entry-document-list>
    </library-entry>
  </storage-library-entry-list>
</storage-request>
```

In the response file, processing status of the request will be added as follows:

```
<storage-request route="A" operation="withdraw-document">
  <storage-library-entry-list>
    <library-entry appl-type="national">
      <document-id><country>FI</country><doc-number>PCT@FI2006@000029</doc-number></document-id>
      <library-entry-document-list>
        <library-entry-document document-type="tpdc" lang="ja"></library-entry-document>
      </library-entry-document-list>
    <processing-status><complete-success/></processing-status>
  </library-entry>
</storage-library-entry-list>
</storage-request>
```

2.6.6 Requests and Response for PDOC document and information

Retrieval requests for PDOC download and business information support the following operations:

- GET-DOCUMENT is used for retrieval of document content and properties (i.e. business information). The response to this request will include document(s), PDOC as well as existing translations.

The following example contains a request to retrieve PDOC content and information of 3 PDOCs in DAS.

```
<retrieval-request operation="get-document">
  <retrieval-library-entry-list>
    <library-entry appl-type="national">
      <document-id><country>US</country><doc-number>11/912,3461</doc-number></document-id>
    </library-entry>
    <library-entry appl-type="national">
      <document-id><country>FI</country><doc-number>123458</doc-number></document-id>
    </library-entry>
    <library-entry appl-type="national">
      <document-id><country>EP</country><doc-number>07122815</doc-number></document-id>
    </library-entry>
  </retrieval-library-entry-list>
</retrieval-request>
```

In the response file, processing status of the request and requested document and information will be added as follows:

```
<retrieval-request operation="get-document">
  <retrieval-library-entry-list>
    <library-entry appl-type="national">
      <document-id><country>US</country><doc-number>11/912,3461</doc-number></document-id>
      <library-entry-document-list>
        <library-entry-document document-type="pdoc">
          <wrapped-document package-type="wad" file="XXXXXXXXXXXX-pdoc-000002-XX-FI-XXXXXXXX-118912,3461-20071203.zip"/>
        </library-entry-document>
      </library-entry-document-list>
      <first-filing-office-confirmation-date><date>20070911</date></first-filing-office-confirmation-date>
      <applicant-confirmation-date><date>20071001</date></applicant-confirmation-date>
      <processing-status><complete-success/></processing-status>
    </library-entry>
    <library-entry appl-type="national">
      <document-id><country>FI</country><doc-number>123458</doc-number></document-id>
      <library-entry-document-list>
        <library-entry-document document-type="pdoc">
          <wrapped-document package-type="wad" file="XXXXXXXXXXXX-pdoc-000002-EN-FI-XXXXXXXX-123458-20071203.zip"/>
        </library-entry-document>
        <library-entry-document document-type="tpdc" lang="zh">
          <wrapped-document package-type="wad" file="XXXXXXXXXXXX-tpdoc-000001-ZH-FI-XXXXXXXX-123458-20071203.zip" lang="zh"/>
        </library-entry-document>
      </library-entry-document-list>
      <first-filing-office-confirmation-date><date>20071104</date></first-filing-office-confirmation-date>
      <applicant-confirmation-date><date>20071204</date></applicant-confirmation-date>
      <processing-status><complete-success/></processing-status>
    </library-entry>
    <library-entry appl-type="national">
      <document-id><country>EP</country><doc-number>07122815</doc-number></document-id>
      <processing-status><complete-rejection>Document not found</complete-rejection></processing-status>
    </library-entry>
  </retrieval-library-entry-list>
</retrieval-request>
```

- GET-PROPERTIES is used for retrieval of properties (i.e. business information). The response to this request will not include document(s).

The following example contains a request to retrieve 3 PDOC entries information in DAS.

```
<retrieval-request operation="get-properties">
  <retrieval-library-entry-list>
    <library-entry appl-type="national">
      <document-id><country>FI</country><doc-number>11/272,866</doc-number></document-id>
    </library-entry>
    <library-entry appl-type="national">
      <document-id><country>EP</country><doc-number>07384949.9</doc-number></document-id>
    </library-entry>
    <library-entry appl-type="national">
      <document-id><country>US</country><doc-number>09/004,420</doc-number></document-id>
    </library-entry>
  </retrieval-library-entry-list>
</retrieval-request>
```

In the response file, processing status of the request and business information will be added as follows:

```
<retrieval-request operation="get-properties">
  <retrieval-library-entry-list>
    <library-entry appl-type="national">
      <document-id><country>FI</country><doc-number>11/272,866</doc-number></document-id>
      <first-filing-office-confirmation-date><date>20070911</date></first-filing-office-confirmation-date>
      <applicant-confirmation-date><date>20071001</date></applicant-confirmation-date>
      <processing-status><complete-success/></processing-status>
    </library-entry>
    <library-entry appl-type="national">
      <document-id><country>EP</country><doc-number>07384949.9</doc-number></document-id>
      <first-filing-office-confirmation-date><date>20071104</date></first-filing-office-confirmation-date>
      <applicant-confirmation-date><date>20071204</date></applicant-confirmation-date>
      <processing-status><complete-success/></processing-status>
    </library-entry>
    <library-entry appl-type="national">
      <document-id><country>US</country><doc-number>09/004,420</doc-number></document-id>
      <first-filing-office-confirmation-date><date>20071104</date></first-filing-office-confirmation-date>
      <applicant-confirmation-date><date>20071104</date></applicant-confirmation-date>
      <processing-status><complete-success/></processing-status>
    </library-entry>
  </retrieval-library-entry-list>
</retrieval-request>
```

2.6.7 Error handling

While system processes the request batch for any operation, there are two possible error cases.

When XML parsing errors are detected by validating the index library-transaction-request.xml against the DTD, the entire batch file will not be processed and an error file will be generated in text format in the appropriate response folder, as follow:

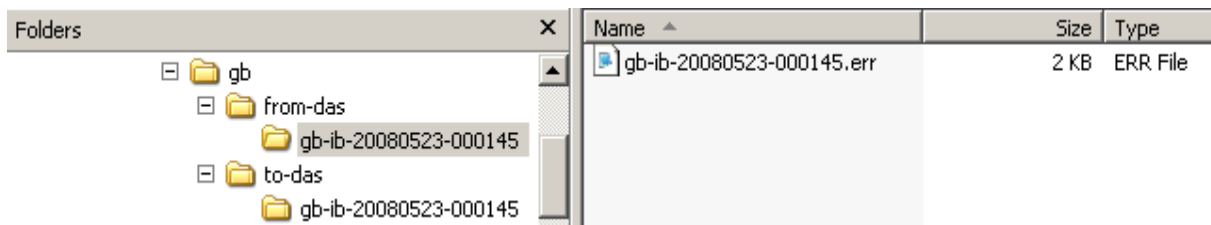

The error file has the name of the batch folder name and followed by ".err". No '.done' will be generated by DAS in this case. The following is an example of XML errors:

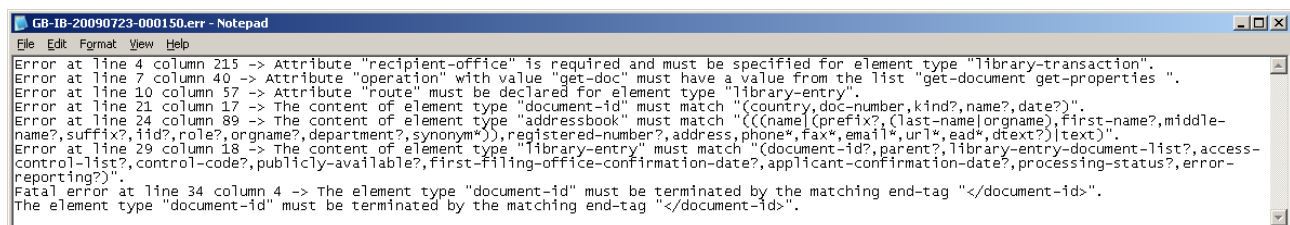

Second type of errors is due to data value constraints that cannot be validated against the DTD. In such cases, error will be reported for the causing operation by indicating an appropriate error code, description and location of the XML element.

```
<?xml version="1.0" encoding="UTF-8" ?>
<!DOCTYPE library-transaction (View Source for full doctype...)>
- <library-transaction transaction-type="response" date-produced="20090825" dtd-version="1.2" file="library-transaction-response.xml"
  country="CN" lang="en" recipient-office="CN" sending-office="IB">
- <storage-request-list>
  - <storage-request route="A" operation="add-entry">
    - <storage-library-entry-list>
      + <library-entry-owner-details>
      - <library-entry appl-type="national">
        - <document-id>
          <country>asdf</country>
          <doc-number>1000001</doc-number>
          <date>20090825</date>
        </document-id>
        - <library-entry-document-list>
          - <library-entry-document document-type="pdoc">
            <wrapped-document package-type="wad" file="XXXXXXXXXXXX-pdoc-000001-XX-CN-20090825-1000001-
              XXXXXXXX.zip" />
          </library-entry-document>
        </library-entry-document-list>
        - <processing-status>
          <complete-rejection errorcode="4">INVALID DATA</complete-rejection>
        </processing-status>
        - <error-reporting>
          <error-location data="yes" structure="no">/library-transaction/storage-request-list/storage-request/storage-library-
            entry-list/library-entry/document-id/country</error-location>
        </error-reporting>
      </library-entry>
    </storage-library-entry-list>
  </storage-request>
</storage-request-list>
</library-transaction>
```

2.6.8 Possible errors

Possible errors are listed in the DTD, as follows:

- <!-- -1 "DUPLICATE (ENTRY ALREADY EXISTS)" -->
- <!-- -2 "INVALID FILE FORMAT" -->
- <!-- -3 "INVALID FILE" -->
- <!-- -4 "INVALID DATA" -->
- <!-- -5 "PDOC WITHDRAWN" -->
- <!-- -6 "ACCESS NOT AUTHORIZED" -->
- <!-- -7 "APPLICATION NUMBER NOT FOUND" -->
- <!-- -8 "FILE WAS NOT AVAILABLE (REQUESTED APPLICATION EXISTS BUT IS NOT CLEARED FOR DISSEMINATION, e.g. security)" -->
- <!-- -9 "DOCUMENT(S) WAS NOT AVAILABLE (COMPLETE SET OF REQUIRED DOCUMENTS FOR CERTIFIED COPY IS NOT AVAILABLE)" -->
- <!-- -10 "NO RESPONSE FROM OFF (REQUEST ENDED AFTER EXPIRATION OF A SPECIFIC TIMELINE (e.g. 30 days))" -->
- <!-- -11 "PDOC CANNOT BE WITHDRAWN (DOCUMENT ALREADY RETRIEVED BY OSF)" -->

2.6.9 Temporary responses

If a PDOC which is known by DAS and has been made available to an OSF (e.g. UKIPO) by the applicant cannot be transmitted to that Office for technical reasons, the following will apply:

- DAS gives a temporary response similar to get-document response for each requested item received for more than 24 hours, for which no temporary response has been given and no response has been received from OFF. But it may happen that DAS receives the response from OFF just seconds after the temporary response is provided.
- Only once and only one temporary response should be given for one request item. It is put inside 'temp-responses' under the corresponding batch folder inside 'from-das', using the same name of the response file.
- Temporary response is given only for GET-DOCUMENT or GET-PROPERTIES operation request item.
- Temporary response file includes the certificate page indicating only the requesting office (1 page PDF file given in the ZIP format).
- Final response will be generated independently and as specified in above sections. So if temporary responses are not useful for a participating office to explore, they can be ignored.

The following is an example of temporary responses structure:

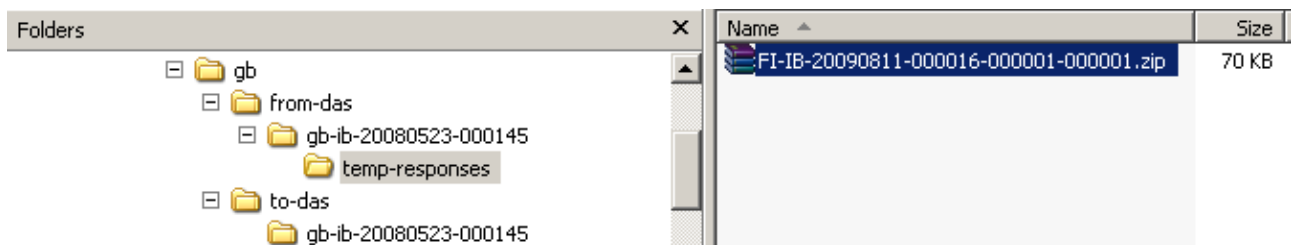

The following is an example of “in-progress” status reporting:

```
<?xml version="1.0" encoding="UTF-8" ?>
<IDOCTYPE library-transaction (View Source for full doctype...)>
- <library-transaction dtd-version="1.2" lang="en" file="library-transaction-response.xml" transaction-type="response" transaction-
id="FI-IB-20090811-000016-000001-000001.zip" date-produced="20090812" country="FI" sending-office="IB" recipient-
office="FI">
- <retrieval-request-list>
- <retrieval-request operation="get-document">
- <retrieval-library-entry-list>
- <library-entry>
- <document-id>
<country>IL</country>
<doc-number>154345</doc-number>
</document-id>
- <library-entry-document-list>
- <library-entry-document document-type="pdoccert">
<wrapped-document package-type="wad" file="XXXXXXXXXXXX-pdoccert-000001-XX-CN-20090320-
200810000100.X-XXXXXXXXX.zip" />
</library-entry-document>
</library-entry-document-list>
- <publicly-available>
<date>20080922</date>
</publicly-available>
- <processing-status>
<in-progress />
</processing-status>
</library-entry>
</retrieval-library-entry-list>
</retrieval-request>
</retrieval-request-list>
</library-transaction>
```

2.6.10 Recommended file naming convention

It is recommended to name the document files (e.g. priority document, certificate page) accordingly to "**Minimal Specifications for Electronic PCT Document Exchange**". PDOC details are given as part of the filename. Following that naming convention and with respect to PDOC used for DAS, filename consists of nine parts as follows:

1. The PCT Number is used only for PCT International Application number. Use the string PCTXXXXXXXXXXXXX or XXXXXXXXXXXXXXXX if the application is non PCT.
2. The document type code in lower case (see the annex of the attached documentation for the document types): 'pdoc' for priority document.
3. A numeric string NNNNNN to make the filename unique within the batch ZIP file. NNNNNN is a number right justified and padded with leading zeros.
4. The upper case ISO639 code representing the language of the document or XX if unknown
5. Two letters filing country code of the PDOC (e.g. GB)
6. Filing date of the application in the format of yyyyMMdd
7. Serial number of the application. if it contains '/' characters, replace by '@', if it contains '\' characters replace by '#', if it contains '-' characters, replace by '^'.
8. Date of Receipt from applicant if applicable 17.1(a) otherwise XXXXXXXX
9. File extension which could be 'zip', 'wad' or 'pdf'.

Let's consider the example for sending a non PCT PDOC to DAS in ZIP format that was received at GB on 19/04/2007, given the filing date 20/04/2007 and the application number 9702130.7, the name of the file should be XXXXXXXXXXXXXXXX-pdoc-000001-XX-gb-20042007-9702130.7-19042007.zip.

2.6.11 Supported file formats

Although only PDF format is supported in the current implementation of TDA 1.7.2, DAS/ PCT-EDI would accept documents transmitted in PDF or TIFF format given in a ZIP package.

The zipped TIFF content takes the form of TIFF image files containing CCITT group 4 300dpi reverse bit order black and white images. The files are named in their page order sequence:

000001.tif
000002.tif
000003.tif
... etc.

Documents will be transmitted to OSFs in the format as received from OFF.

2.7 Cover page for priority documents

For priority documents, a cover page is added by DAS to given all business information as follows:

Document details:		
Country/Office:	ES	Filing date: 22 Sep 2009 (22.09.2009)
Application number:	P 200930006	
Date of availability of document: 22 Sep 2009 (22.09.2009)		
Availability to Office: EP [22 Sep 2009 (22.09.2009)]		
Date of issue of this certificate: 22 Sep 2009 (22.09.2009)		
		
<small>World Intellectual Property Organization (WIPO) – Geneva, Switzerland Organisation Mondiale de la Propriété Intellectuelle (OMPI) – Genève, Suisse</small>		

Date of availability of the document is the date when the priority document entry is added into DAS. For Routes A and B entries, it is the date of receipt of the ADD-ENTRY request at DAS. For Route C entry, it is date when applicant first uses DAS portal to confirm availability of the document.

Date of availability to office is the earliest of the date when access permission is given to that office by the applicant via DAS portal and the publication date of the document which is communicated to DAS by OFF.

2.8 Usage of application numbers

DAS applies the following rules in interpretation of application numbers (see WIPO Standard [ST10/C](#)):

- Application numbers are added into DAS Database without case conversion and characters substitution when ADD-ENTRY operations are recorded upon receipt in DAS.
- Following characters substitution when system looks for DB records with regard to the application given by OSF at retrieval (e.g. kind of pattern matching)
- Application numbers used by DAS in processing retrieval requests from OSF will be case insensitive
- All space, full stop, comma characters will be ignored by DAS in processing retrieval requests from OSF
- Check digit (a numeral from '0' to '9' or a case insensitive letter from 'a' to 'z') that comes after the application number and preceded by full stop or hyphen will be ignored by DAS in processing retrieval requests from OSF
- If the Greek character " π " (pi) is recorded in DAS, it will be considered as "P" in processing retrieval requests from OSF.

2.8.1 Add PDOC entry to DAS

p-doc entry should be added into DAS in such a way that documents can be retrieved either from its storage because a copy has been transmitted to store in DAS, or from the digital library of the OFF. That would depend on the search mechanism implemented in the digital library of the OFF to find the requested application. So priority document details can be added into DAS, as follows:
As certified copy, both two letter country code of the OFF (e.g. JP) and the application number (e.g. 2009123456) should be given.

As a copy of priority document the priority of which is claimed and stored in another application, document details should include:

- Information about the application claiming priority and holding the copy of priority document (two letter country code of the OFF (e.g. JP) and the application number (e.g. 2005123456).
- Information about the priority document (two letter country code of the depositing office where it was originally filed and the priority application number, e.g. JP 200612345 or VN 0612345)

2.8.2 Retrieve PDOC from DAS

For retrieval, priority document can be retrieved from DAS by giving only the priority application number, independently on how the entry was added to DAS as described above.

2.9 Optional business data

Some other business data such as filing date and publication date of the application can be transmitted to DAS either when entry is added to DAS or in response to a document request. At the time of writing this document, this is applicable only to TDA implementation.

2.10 Bilateral arrangement

Some technical arrangement can be put in place to facilitate support and monitoring of exchange between DAS and participating offices on a bilateral basis.

- EXPIRED_TRANSACTION: If a retrieval request from an OSF is pending for getting a response from OFF and exceeds an agreed timeline (e.g. 14 days in case of GB), DAS will close the transaction by giving a final negative response with error code -10. The response given by the OFF after that will not be communicated to OSF.
- CHANGE OF REGISTERED STATUS: under the TDA exchange, a second das-response can be resent to DAS by the OFF when the status of the requested application is changed from 'NOT REGISTERED' to 'REGISTERED' although a first das-response was given with 'NOT REGISTERED' status. A second e-mail will be given to inform the applicant of this status change.
- E_MAIL NOTIFICATION to Offices: if office e-mails are registered and dedicated to monitoring operation and support issues in participating offices which implement PCT-EDI, DAS will send e-mail notifications upon detection of unexpected request and response data. For instance, if publication dates given twice in TDA/dasresponse and TDA/pdresponse are different for the same application, notification alert can be sent to OFF.

3 Flow of data for Route A or B

Route A or B is implemented under PCT-EDI framework.

3.1 OFF to DAS

This scenario describes the flow of an OFF request submitted via PCT-EDI to DAS to add PDOCs into DAS.

1. OFF uploads one or many batch files into the SFTP **to-das** folder of that office.
2. Upon disconnection event of the OFF, a trigger program is activated to add one message to the Queue/EDIREquests for each request batch file received (i.e. Office code and path of the request batch file inside that office).
3. The DAS-business listener process is triggered to read the message from Queue/EDIREquests. It downloads all the existing batch files for that particular office code. It unzips the files and records the DAS requested operations into DAS database.
4. The DAS-business listener process generates a DAS response batch file for each requested operation and copies it to the **from-das** folder of the requesting Office. DAS response may contain error feedback for any incoming requested operation that cannot be fulfilled. After processing all requested operations either successfully or unsuccessfully, the request batch file should be deleted from **to-das** folder. Any invalid request batch files should be recorded in DAS and the corresponding files in the **to-das** will be deleted (please refer to the above CN example).

OFF To DAS
 (Add PDOC Data Flow under Route A or B via PCT/EDI)

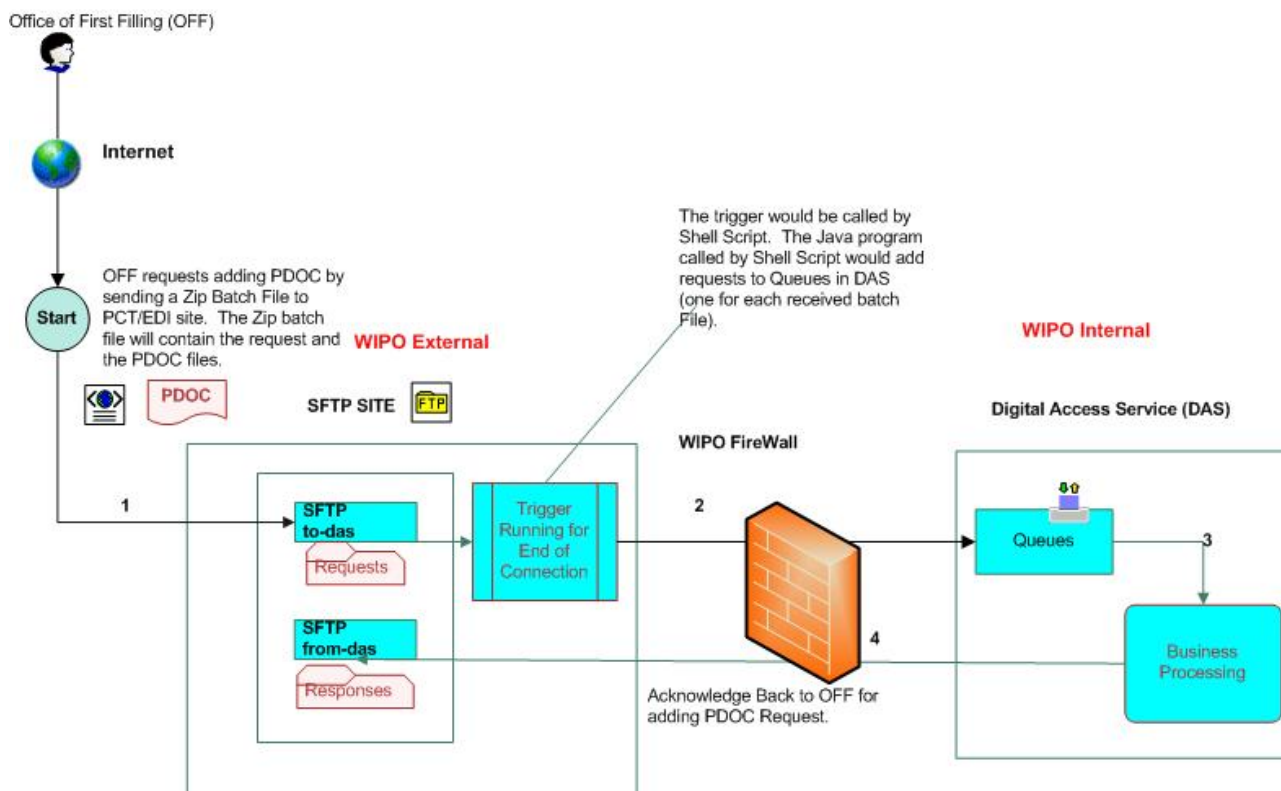

3.2 OSF to DAS via PCT-EDI

This scenario describes the flow of an OSF request submitted via PCT-EDI to DAS to retrieve PDOCs. If a batch requests many items, one DAS response file will be made available to office as soon as the requested operation is completed. This means some request items may encounter failure of system or business error. If DAS does not have the requested document, it will handle the appropriate query to OFF to get it. The delay of each response depend on the availability of the system in OFF. DAS will handle and re-send requests if needed (e.g. TDA implementation). In the worse case, after several unsuccessful attempts to retrieve the items via TDA, partially fulfilled responses can be sent back to OFF in different responses packages on different dates.

One possible implementation of the business processing is to use a status (pending, error, requesting OFF and success) and two timestamps (start-up and last process timestamps):

- All items start with pending status and start-up timestamp.
 - If a requested item can be fulfilled within DAS, provide the appropriate response and update the last process timestamp.
 - If a requested item is hosted in OFF, call the TDA web service or send a PCT-EDI request batch to OFF, set the status 'requesting OFF' and update the last process timestamp.
1. The OSF uploads one or many batch request files into the SFTP **to-das**.
 2. Upon disconnection event of the OSF, a trigger program is activated to add one message the Queue/EDIRRequests for each request batch file received (i.e. Office code and path of the batch request file inside that office).
 3. The DAS-business listener process is triggered to read the message from Queue/EDIRRequests. It downloads all the incoming request batch files for that particular office. Any invalid files should be recorded in DAS and the corresponding files in the **to-das** will be deleted. It first unzips each request batch file and applies the following processing for each valid DAS request item (see also some other possible implementations above).
 4. If the requested PDOC is available in DAS, the system updates status and timestamps to prepare the response package.
 5. If the requested PDOC is not available in DAS because it has been recorded as 'PDOC hosted in OFF', the system calls OFF via TDA web service or send a PCT-EDI request batch to OFF to retrieve it. The TDA acknowledgement ID should also be recorded. The system updates status and timestamps to prepare the response package. In the current specification of TDA, there is no timeout mechanism to close the pending operation. DAS will provide a system monitoring feature to follow-up these cases.
 - a. Upon receipt of OFF response for the requested PDOC, the system transfers the response to Queue/OFFResponses.
 - b. The DAS-business listener process is triggered to read the message from Queue/OFFResponses. It records the OFF response and updates status and timestamps to prepare the response package (i.e. success or failure).
 6. If all the requested items are completely processed (status can be **error** or **success**), the system will generate a DAS response status and copy it to the **from-das** of the requesting Office (please refer to the above CN example). If Applicant has not granted access to the requested Office for the priority document, an 'Access denied' message will be sent. Only after all items are successfully processed, the batch file should be deleted from **to-das** folder.

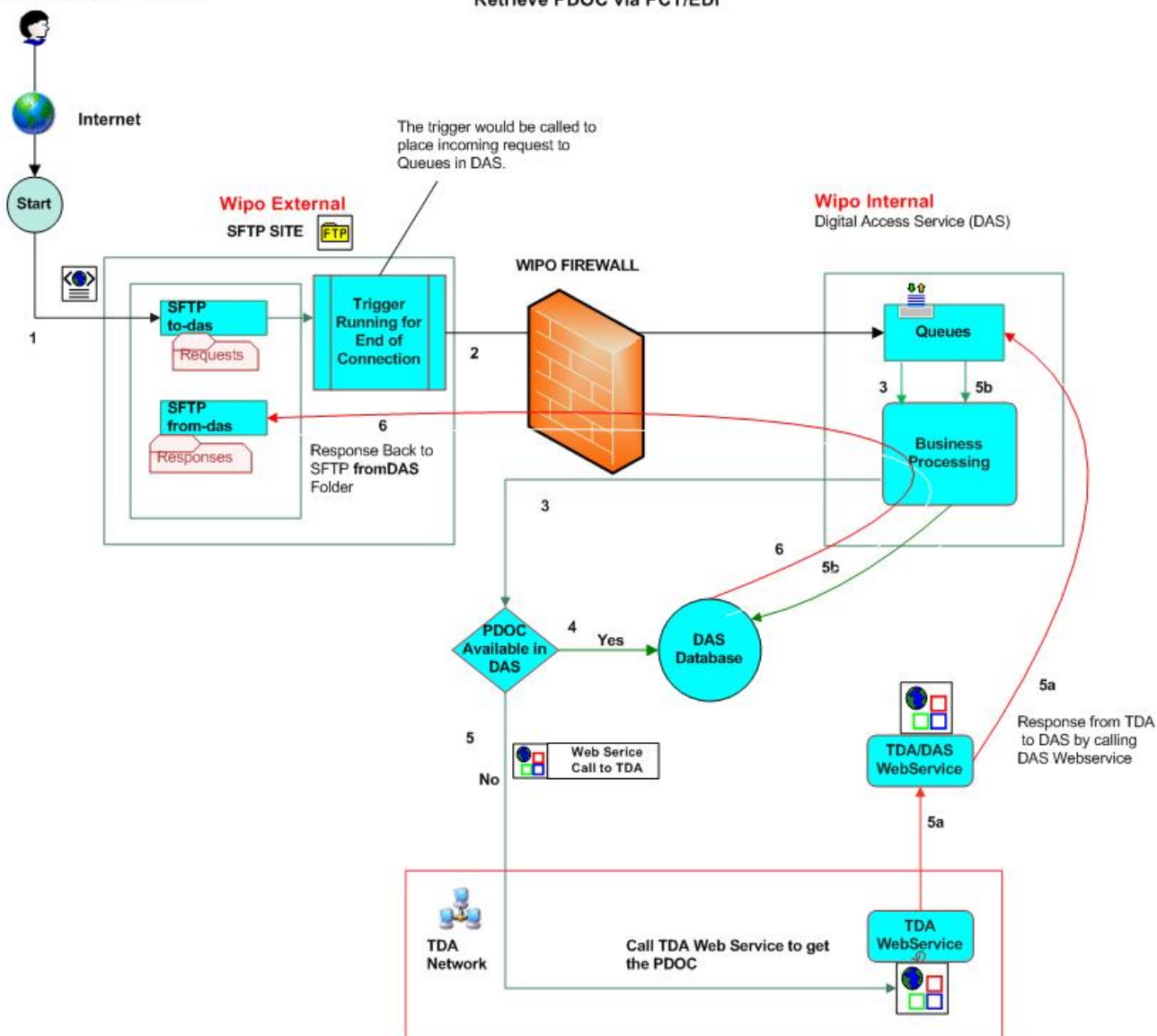

3.3 OSF to DAS via TDA

This is the scenario for the OSF to retrieve the PDOC from DAS via TDA framework.

1. OSF calls the DAS Web service for a PDOC. The PDOC reference and Country code would be passed along with the web service request.
2. The DAS Web service handles the request, by:
 - a. registering the TDA request into the TDARRequests Queue,
 - b. sending back an acknowledgment ID to the caller.
3. The DAS-business listener process is triggered to read the message from Queue/TDARRequests. It processes the request by checking whether the PDOC is available in DAS System.
4. If the requested PDOC is available in DAS, the following processing is applied:
 - a. The system updates status and timestamps of the request in the database.
 - b. It sends the requested PDOC to OSF via TDA. The scenario ends here.

5. If the requested PDOC is not available in DAS because it has been recorded as 'PDOC hosted in OFF', the system calls the hosting OFF via TDA web service or send a PCT-EDI request batch file to OFF to retrieve it. The system updates status and timestamps to prepare the response.
 - a. Upon receipt of TDA response from the hosting OFF for the requested PDOC, the system transfers the response to Queue/OFFResponses.
 - b. The DAS-business listener is triggered to read the message from Queue/OFFResponses.
 - c. It records the OFF response and updates status and timestamps to prepare the response (i.e. success or failure). The system sends back the response to OSF through TDA.

N.B. Normally, TOs would use the existing framework to exchange documents among them and it is not necessary to go through DAS. But if Applicants has requested OFF to use DAS framework for the exchange, OFF has to add the priority document reference into DAS so that any requests from OSF can be fulfilled.). If Applicant has not granted access to the requested Office for the priority document, an 'Access denied' message will be sent.

Retrieve PDOC via DAS/TDA

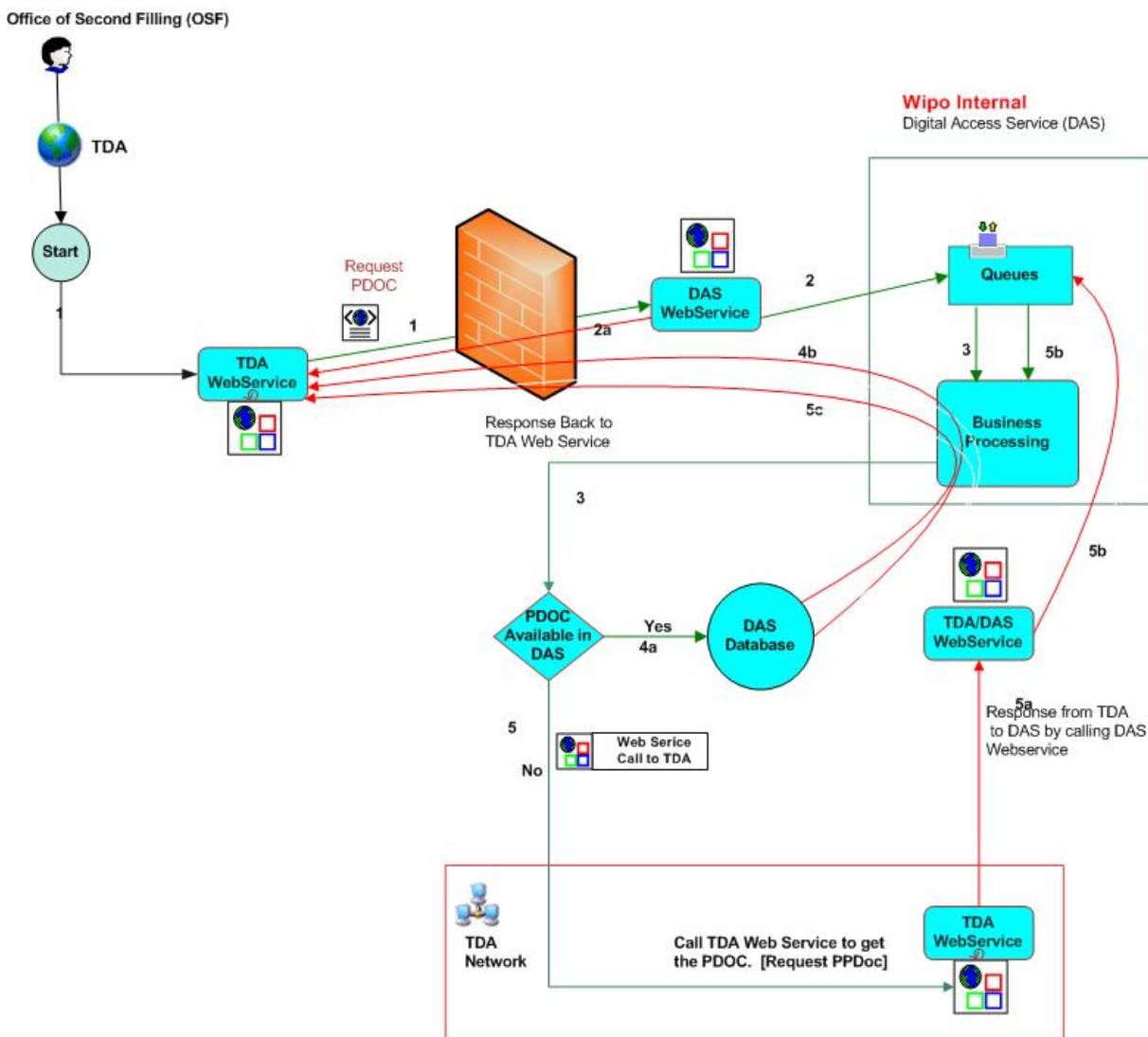

3.4 Web Applicant to DAS (manage access control list)

This scenario describes the flow of a Web applicant to DAS to setup or manage a country list of Offices of Second Filing (OSF) to grant access permissions. If PDOC is publicly available or has already been accessed by an OSF, the withdrawal of permission access for that OSF will not be allowed. There is an intention to implement a mechanism for OFF and DAS to communicate the publication status of priority documents. This might not be implemented in the initial setup of DAS, but Applicant may also set the status from the DAS web portal, by specifying a date on and after that the priority documents can be retrieved by any OSF.

1. Applicant accesses the DAS web portal to manage the access control list. He needs to type the PDOC reference, email and access control code. System validates the country code (i.e. client side validation) in PDOC number.
2. The web container servlet will pass the request to WebRequests Queue.
3. The DAS-business listener is triggered to read the message from Queue/WebRequests. System checks the validity of PDOC number. If invalid, it will send a response back to Web Applicant.
4. If the PDOC is valid, System checks whether the requested PDOC has been delivered to any OSFs. If it has been delivered the withdrawal of permission access for those OSFs will not be allowed. System will not allow Applicant to change the access control list if PDOC is publicly available.
5. System then displays the Web Page with Access Control List of the OSFs. As mentioned above the applicant can able to modify the access permissions except the above conditions specified in point 4.
6. User updates the Access Control List and submits his changes. DAS System would then save the updated Access Control information and then intimate the user by displaying the Updated Message in Webpage.
7. The rest of the dataflow can be implemented at a later stage based on the preferred option of OSF.

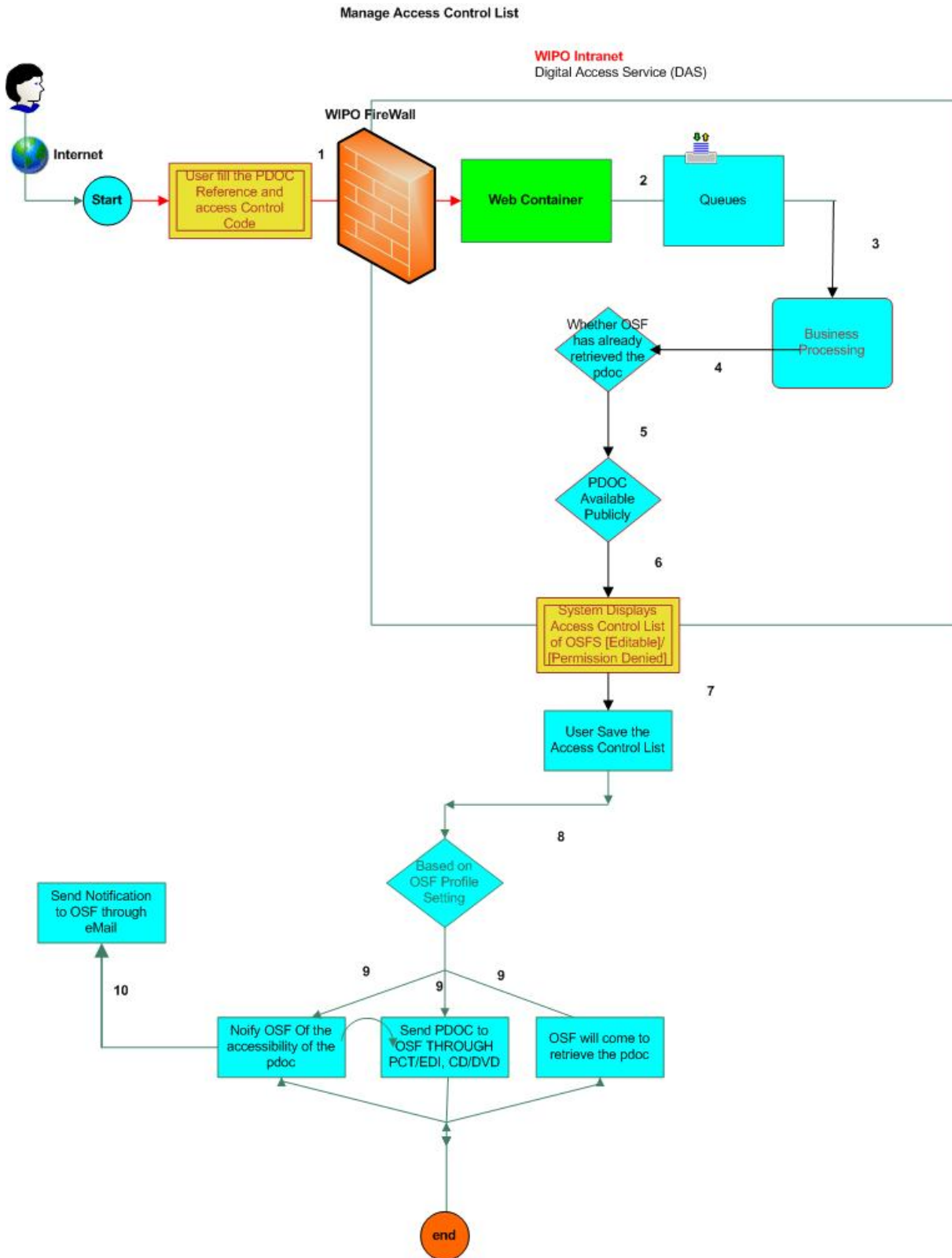

3.5 Web Applicant to DAS (query PDOC availability)

The PDOC availability means the PDOC reference has been added to DAS, it does not confirm if the PDOC document content is actually accessible in DAS or TDA. This scenario describes the flow of a Web applicant to check the PDOC Availability in DAS.

1. Applicant accesses the DAS web portal to check the PDOC Availability. He keys in the PDOC number and access control code in Web page. Once submitted the flow will proceed to Step 2.
2. The web container servlet will pass the request to Queuing Server.
3. The DAS-business listener is triggered to read the message from Queue/WebRequests.
4. System checks the validity of PDOC number. If invalid, it will send a response back to Web Applicant.
5. If the PDOC is valid, System checks whether the requested PDOC is available in DAS. If it's available, System will then display the availability details to Web applicant.
6. If the PDOC is recorded as 'hosted by OFF' and TDA supports synchronous request for this purpose, system will make a TDA call to check the availability and display the result back to the Applicant in real time.
7. If the PDOC is recorded as 'hosted by OFF' and TDA supports asynchronous request for this purpose, system will make a TDA call, but an appropriate message will be displayed to inform Applicant that his request has been registered and forwarded to OFF and a notification for confirmation on paper or e-mail will be sent when the response is ready:
 - a. System sends a TDA request to OFF and registers the acknowledgement ID.
 - b. Upon receipt of TDA response from the hosting OFF for the requested PDOC, the system transfers the response to Queue/OFFResponses.
 - c. The DAS-business listener process is triggered to read the message from Queue/OFFResponses.
 - d. It records the OFF response and sends back the response Applicant on paper or by e-mail.

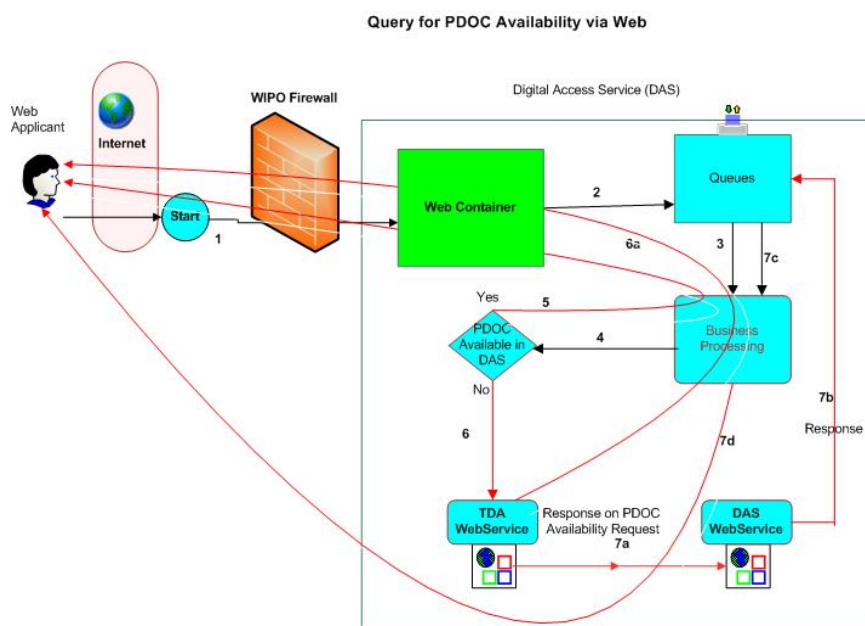

3.6 OSF to DAS via PCT-EDI (query PDOC availability)

This scenario describes the flow of an OSF to check the PDOC Availability in DAS.

1. OSF uploads requests into DAS Inbox using batch files.
2. Upon disconnection event, a trigger program is activated to add one message to the Queue/EDIRequests for each batch file received (i.e. Office code and path of the batch file inside that office internal Inbox).
3. The DAS-business listener processed is triggered to read the message from Queue/EDIRequests. It downloads all the existing request batch files for that particular office code. Any invalid files should be recorded in DAS and the corresponding files in the **to-das** will be deleted. It performs the business processing as follows:
 - a. It unzips the batch files and processes each valid DAS request item (see possible implementation above).
 - b. If the requested PDOC is available in DAS, the system updates status and timestamps to prepare the response package.
 - c. If the requested PDOC is not available in DAS because it has been recorded as 'PDOC hosted in OFF', the system updates status and timestamps to prepare the response package.
4. The detailed of the TDA or PCT-EDI exchange is similar to sequences 6 and 7 of the previous scenario.
5. Once all the requested items are completely processed (status can be **error** or **success**), the system generates a DAS response status and copies it to the **from-das** of the requesting Office. Only after all items are successfully processed, the batch file should be deleted from **to-das** folder.

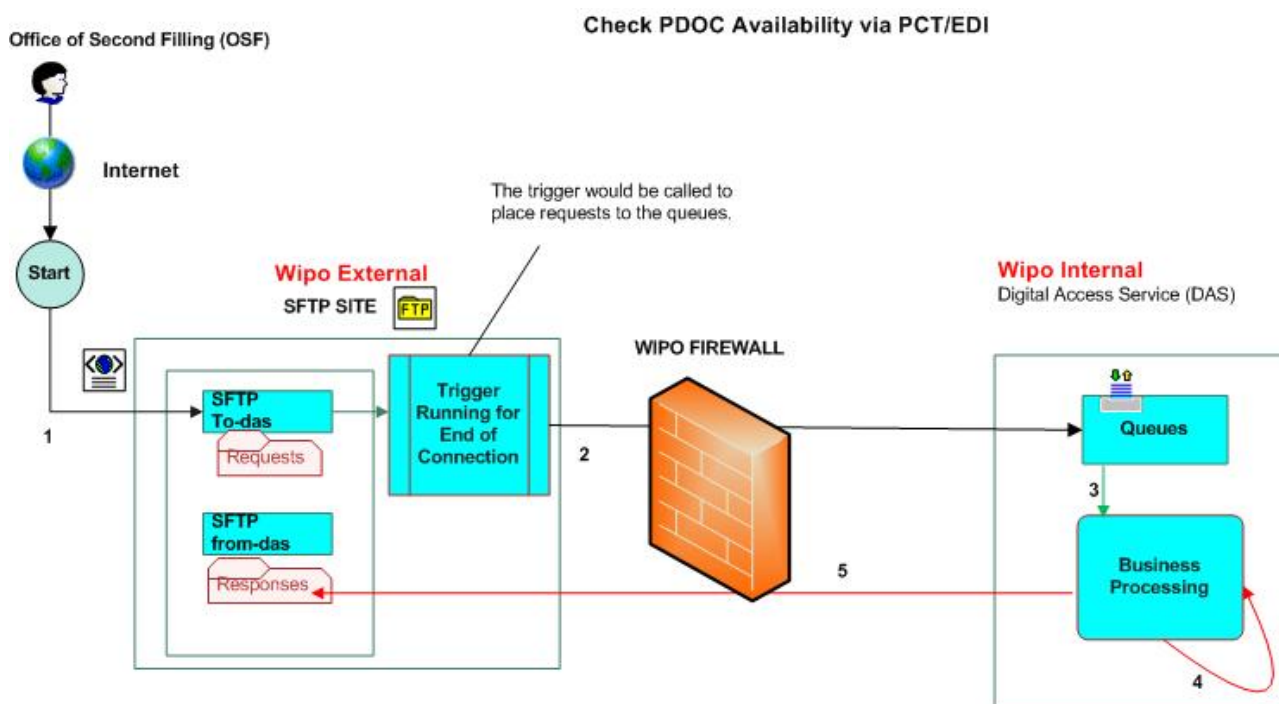

4 Recommendations for implementation

For a first implementation of DAS system, access control code generated by DAS will be 8-digits numeric value. However, access codes that are allotted by OFF or Applicant can be alphanumeric value and should have more than 4 characters case sensitive (i.e. [a-z], [A-Z] and [0-9]).

It is recommended for DAS to provide an on-line access code generation service (i.e. a web service), but consultation with Offices will be required before any implementation.